

Ignition Coil P65-WS



- ▶ Max. 35 kV
- ▶ Min. 65 mJ
- ▶ Connection for high voltage wire according to SAE (American standard)
- ▶ Max. 10,000 1/min
- ▶ Developed for GDI engines

This single fire coil is a low cost concept, designed to get connected to the spark plug via a high voltage wire. The high voltage connector is specified according to the SAE standard.

The performance of the coil fulfills the demands of modern GDI engines.

The main benefits of this product are the high packaging flexibility and its high electrical performance at low costs.

Application

Spark energy	≥ 65 mJ
Primary current	≤ 7.5 A
Operating temperature range at outer core	-20 to 140°C
Storage temperature range	-40 to 100°C
Max. vibration	≤ 250 m/s ² at 5 to 2,500 Hz

Technical Specifications

Mechanical Data

Length	See offer drawing
Weight w/o wire	< 222 g
Mounting	Screw fastening

Electrical Data

Primary resistance	570 mOhm
Secondary resistance	Incapable of measurement
High voltage rise time	≤ 1.9 kV/μs
Max. high voltage at 1 MOhm 10 pF	≤ 35 kV
Spark current	≤ 74 mA

Spark duration at 1 kV 1 MOhm	≤ 2.0 ms
Noise suppression	Inductive and 1 kOhm resistance
Suppression diode / EFU	Integrated

Characteristic

Measured with power stage	IGBT IRG4BC40S (U _{ce} =600 V)
---------------------------	---

Connectors and Wires

Connector	Tyco AMP
Mating connector	D261.205.350-01
Pin 1	Engine GND
Pin 2	U _{batt}
Pin 3	ECU ignition power stage

Characteristic dwell times [ms]

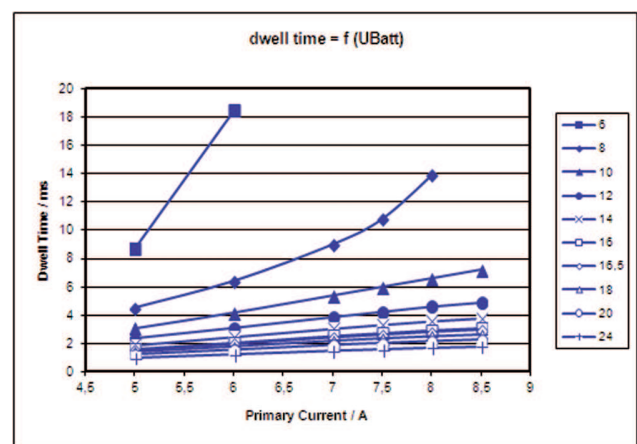

Dwell time

U _{batt}	I primary					
	5.0A	6.0A	7.0A	7.5A	8.0A	8.5A

6V	8.74	18.5				
8V	4.5	6.4	9	10.8	13.9	
10V	3.1	4.2	5.4	6	6.6	7.2
12V	2.36	3.1	3.88	4.25	4.63	4.92
14V	1.9	2.48	3.05	3.32	3.57	3.77
16V	1.61	2.06	2.53	2.73	2.93	3.08
18V	1.55	2	2.43	2.62	2.81	2.95
20V	1.39	1.77	2.16	2.33	2.48	2.6
22V	1.22	1.54	1.88	2.02	2.15	2.26
24V	0.97	1.23	1.49	1.6	1.71	1.78

Measured values are without loom resistance. Loom resistance must be less than the primary resistance. The needed dwell time is to be verified through current measurement

Spark energy and provided high voltage

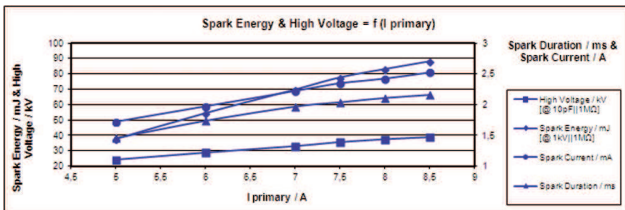

Spark energy

I prim.	Spark energy	-duration	-current	Hi voltage
5 A	37.8 mJ	1.46 ms	49 mA	24.3 kV
6 A	54.5 mJ	1,74 ms	59 mA	28.9 kV
7 A	69.8 mJ	1.97 ms	69 mA	33.2 kV
7.5 A	77.6 mJ	2.04 ms	74 mA	35.8 kV
8 A	83.0 mJ	2.11 ms	77 mA	37.7 kV

8.5 A	88.0 mJ	2.16 ms	81 mA	39.0 kV
-------	---------	---------	-------	---------

Installation Notes

During mounting of the spark plug please pay attention that full clamping and proper contacts are made to ensure safe connection between coil and spark plug.

The coil P65 has no integrated transistor and requires an ECU with internal ignition power stages, e.g. IGBT IRG4BC40S or BIP. For technical reasons the values of the coils may vary.

Please regard the specified limit values.

Please find further application hints in the offer drawing at our homepage.

In case of ignition-caused malfunctions, please use screened sensor wires.

Design Note

We strongly recommend the design of the spark plug shaft has to ensure that there are no sharp edges in the shaft geometry due to design or machining. Only in compliance with this recommendation, a proper function can be ensured.

Legal Restrictions

Due to embargo restrictions, sale of this product in Russia, Belarus, Iran, Syria, and North Korea is prohibited.

Ordering Information

Ignition Coil P65-WS
Order number **F02U.V01.926-01**

Dimensions

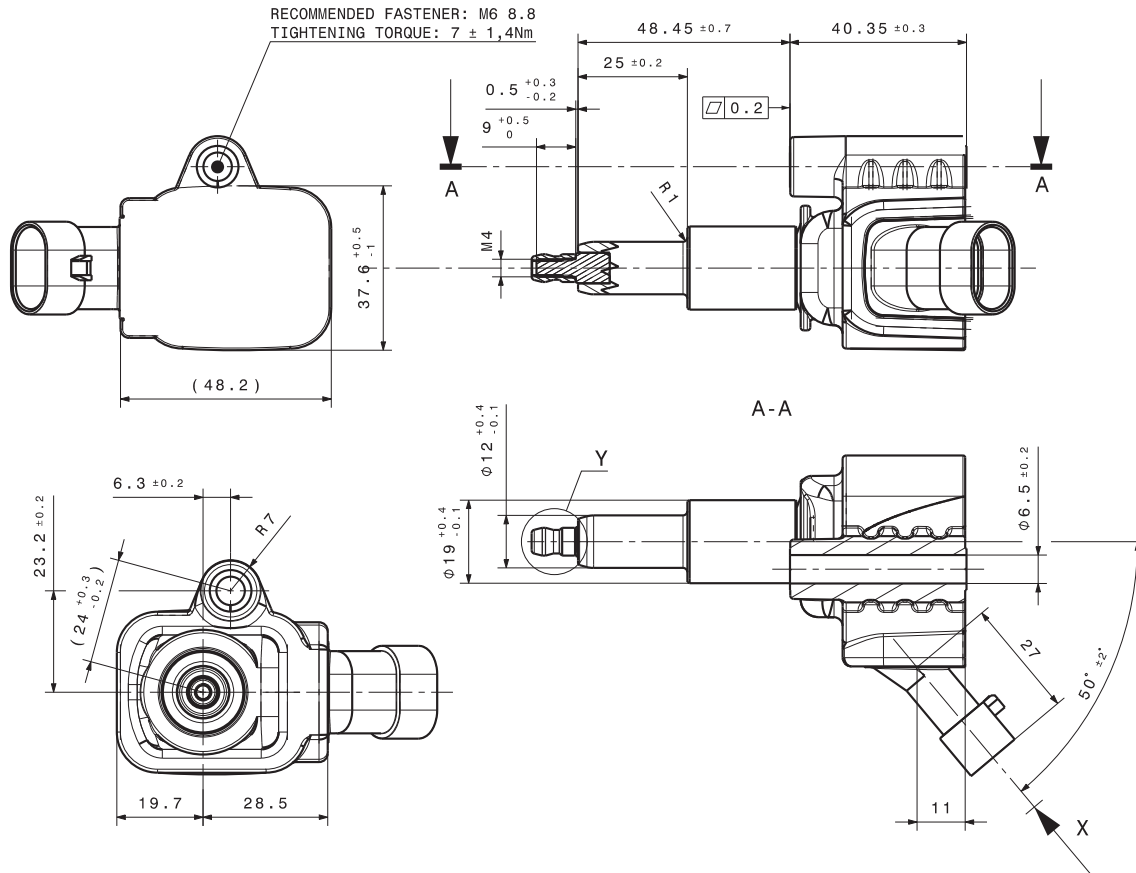

Represented by:

Europe:
Bosch Engineering GmbH
Motorsport
Robert-Bosch-Allee 1
74232 Abstatt
Germany
Tel.: +49 7062 911 9101
Fax: +49 7062 911 79104
motorsport@bosch.com
www.bosch-motorsport.de

North America:
Bosch Engineering North America
Motorsport
38000 Hills Tech Drive
Farmington Hills, MI 48331-3417
United States of America
Tel.: +1 248 876 2977
Fax: +1 248 876 7373
motorsport@bosch.com
www.bosch-motorsport.com

Asia-Pacific:
Bosch Engineering Japan K.K.
Motorsports Department
1-9-32 Nakagawa Chuo, Tsuzuki-ku
Yokohama City
Kanagawa Prefecture 224-8601
Japan
Tel.: +81 45 605 3032
Fax: +81 45 605 3059
www.bosch-motorsport.jp

Australia, New Zealand and South Africa:
Robert Bosch Pty. Ltd
Motorsport
1555 Centre Road
Clayton, Victoria, 3168
Australia
Tel.: +61 (3) 9541 3901
motor.sport@au.bosch.com